



Durable, Low-Maintenance Aluminum Sunshades

- Pre-designed and pre-fabricated to save on engineering, installation and waterproofing costs
- 30% savings when Aluminum vs. Steel materials are used
- Ideal for multi-family housing, office buildings, and condos
- Lightweight yet exceptionally durable



PRE 3

PRE-DESIGNED • PRE-ENGINEERED • PRE-FABRICATED

# ALUMINUM DESIGN VS. TRADITIONAL STEEL

	AS&D Aluminum Sunshade Systems	Steel
Pre-fabricated and painted for faster installation and easy waterproofing	✓	✗
Lightweight: easy to handle and move on the job site	✓	✗
Uniform factory production	✓	✗
Cost effective delivery options: <ul style="list-style-type: none"> <li>• Pre-cut extrusions</li> <li>• KD (knock-down)</li> <li>• Pre-assembled</li> <li>• Pre-drilled holes</li> </ul>	✓	✗
Choice of baked-on enamel, powder coat, and anodized finishes	✓	✗
Can be modified and assembled on site using standard chop saw and drill	✓	✗
Virtually maintenance free: no rust, rot, swelling, splits or cracking	✓	✗

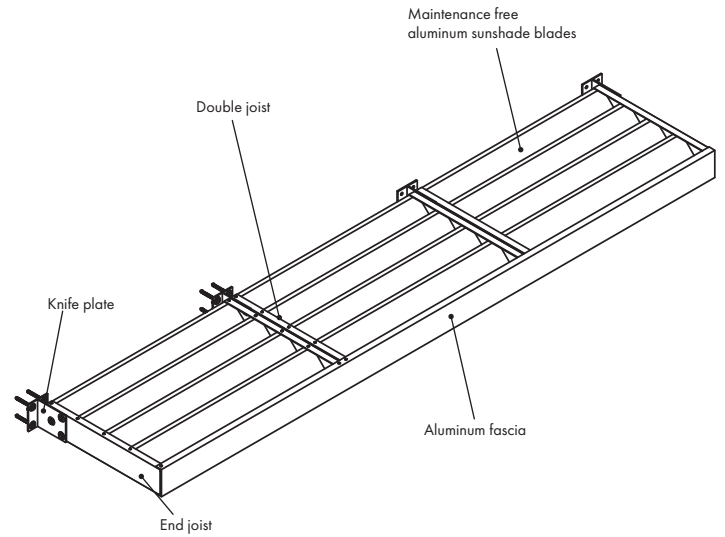

Units include: blades, joists, fascia and mounting hardware

## COMBINE SUNSHADES WITH OUR BALCONY SYSTEM

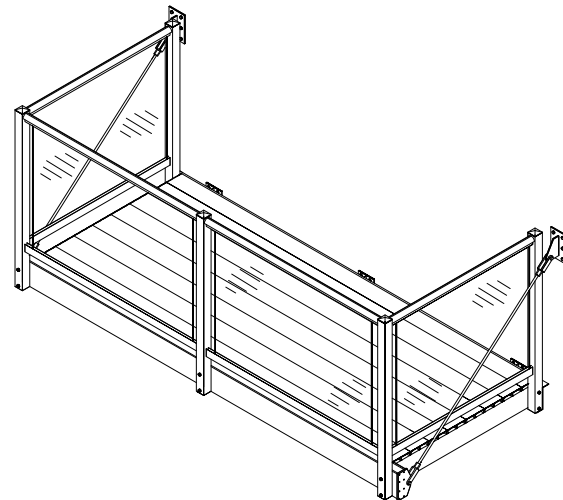

### CHOOSE AN TOP RAIL STYLE



### CHOOSE AN INFILL OPTION



24-HOUR QUOTE TURNAROUND



LEED CERTIFIED



MADE IN AMERICA



NATIONWIDE DISTRIBUTION



AS&D Aluminum Sunshade



Traditional Steel



American Structures & Design Inc. - WA  
218 Stewart Rd. SE Pacific, WA 98047  
P: 253-833-4343 F: 253-833-4545

American Structures & Design Inc. - OR  
13444 NE Jarrett St. Portland, OR 97230  
P: 971-645-4201 F: 971-645-4212