



CERTIFICATION



#1131
ISO/IEC 17065
Product Certification Body



Approved. Sealed. Code Compliant.

Technical Evaluation Report

TER 1808-02

Strong-R® Structural Insulation

Ox Engineered Products, LLC

Product:

Strong-R® Structural Insulation

Issue Date:

November 8, 2018

Revision Date:

September 5, 2019

Subject to Renewal:

April 1, 2020



Technical Evaluation Report (TER)

Strong-R® Structural Insulation

TER No. 1808-02

Issue Date: November 20, 2018

Updated: September 5, 2019

Subject to Renewal: April 1, 2020

Ox Engineered Products, LLC

22260 Haggerty Rd Ste 365

Northville, MI 48167-8970

989-798-5923

oxengineeredproducts.com

1255 N 5th St

Charleston, IL 61920-1175

269-435-2425

DIVISION: 06 00 00 – WOOD, PLASTICS AND COMPOSITES

Section: 06 12 00 – Structural Panels

Section: 06 12 19 – Shear Wall Panels

Section: 06 16 00 – Sheathing

DIVISION: 07 00 00 – THERMAL AND MOISTURE PROTECTION

Section: 07 21 00 – Thermal Insulation

Section: 07 25 00 – Water-Resistive Barriers/Weather Barriers

Section: 07 27 00 – Air Barriers

1. Products Evaluated:

- 1.1. Strong-R® Structural Insulation
- 1.2. For the most recent version of this Technical Evaluation Report (TER), visit drjcertification.org. For more detailed state professional engineering and code compliance legal requirements and references, visit drjcertification.org/statelaw. DrJ is fully compliant with all state professional engineering and code compliance laws.
- 1.3. This TER can be used to obtain product approval in any country that is an IAF MLA Signatory (all countries found [here](#)) and covered by an [IAF MLA Evaluation](#) per the [Purpose of the MLA](#) (as an example, see [letter to ANSI](#) from the Standards Council of Canada). Manufacturers can go to jurisdictions in the U.S., Canada and other [IAF MLA Signatory Countries](#) and have their products readily approved by authorities having jurisdiction using [DrJ's ANSI accreditation](#).
- 1.4. Building code regulations require that evaluation reports are provided by an approved agency meeting specific requirements, such as those found in [IBC Section 1703](#). Any agency accredited in accordance with ANSI ISO/IEC 17065 meets this requirement within ANSI's scope of accreditation. For a list of accredited agencies, visit ANSI's [website](#). For more information, see drjcertification.org.
- 1.5. Requiring an evaluation report from a specific private company (i.e., ICC-ES, IAPMO, CCMC, DrJ, etc.) can be viewed as discriminatory and is a violation of international, federal, state, provincial and local anti-trust and free trade regulations.
- 1.6. DrJ's code compliance work:
 - 1.6.1. Conforms to code language adopted into law by individual states and any relevant consensus based standard such as an ANSI or ASTM standard.
 - 1.6.2. Complies with accepted engineering practice, all professional engineering laws and by providing an engineer's seal DrJ takes professional responsibility for its specified scope of work.

Technical Evaluation Report (TER)

2. Applicable Codes and Standards:¹

- 2.1. 2012, 2015 and 2018 International Building Code (IBC)
- 2.2. 2012, 2015 and 2018 International Residential Code (IRC)
- 2.3. 2012, 2015 and 2018 International Energy Conservation Code (IECC)
- 2.4. 2014 and 2017 Florida Building Code (FBC) (FL 16410)
- 2.5. ASCE/SEI 7 – Minimum Design Loads for Buildings and Other Structures
- 2.6. ASTM C518 – Standard Test Method for Steady-State Thermal Transmission Properties by Means of the Heat Flow Meter Apparatus
- 2.7. ASTM E2126 – Standard Test Methods for Cyclic (Reversed) Load Test for Shear Resistance of Vertical Elements of the Lateral Force Resisting Systems for Buildings
- 2.8. ASTM E2178 – Standard Test Method for Air Permeance of Building Materials
- 2.9. ASTM E330 – Standard Test Method for Structural Performance of Exterior Windows, Doors, Skylights and Curtain Walls by Uniform Static Air Pressure Difference
- 2.10. ASTM E331 – Standard Test Method for Water Penetration of Exterior Windows, Skylights, Doors, and Curtain Walls by Uniform Static Air Pressure Difference
- 2.11. ASTM E564 – Standard Practice for Static Load Test for Shear Resistance of Framed Walls for Buildings
- 2.12. ASTM E84 – Standard Test Method for Surface Burning Characteristics of Building Materials
- 2.13. NFPA 286 – Standard Methods of Fire Tests for Evaluating Contribution of Wall and Ceiling Interior Finish to Room Fire Growth

3. Performance Evaluation:

3.1. Strong-R® Structural Insulation was evaluated to determine:

3.1.1. Structural performance under lateral load conditions (wind and seismic) for use as an alternative to the provisions of [IRC Section R603.9](#).

3.1.1.1. [Table 2](#) provides seismic design coefficients (SDC) that conform to the requirements in ASCE 7 Section 12.2.1 and Table 12.2-1 for design of wall assemblies in buildings that require seismic design in accordance with ASCE 7 (i.e., all seismic design categories).

3.1.1.2. The basis for equivalency testing is outlined in Section 12.2.1 of ASCE 7:

Seismic force-resisting systems not contained in Table 12.2-1 are permitted provided analytical and test data are submitted to the authority having jurisdiction for approval that establish their dynamic characteristics and demonstrate their lateral force resistance and energy dissipation capacity to be equivalent to the structural systems listed in Table 12.2-1 for equivalent values of response modification coefficient, R, overstrength factor, Ω_o , and deflection amplification factor, C_d .

3.1.1.3. The SDC evaluation uses the approach found in documentation entitled “Equivalency Characteristics and Parameters for Proprietary Shear Walls Used in Wood Framed or Cold-formed Steel Construction”² and “Seismic Design Coefficients: How they are determined for light-frame components”³ using code-defined accepted engineering procedures, experience, and technical judgment.

3.1.2. Resistance to uplift loads for wall assemblies used for light-frame cold-formed steel and wood construction in accordance with [IRC Section R301.2.1](#) and [IBC Section 1609](#).

¹ Unless otherwise noted, all references in this code compliant technical evaluation report (TER) are from the 2018 version of the codes and the standards referenced therein, including, but not limited to, ASCE 7, SDPWS and WFCM. This product also complies with the 2000-2015 versions of the IBC and IRC and the standards referenced therein. As required by law, where this TER is not approved, the building official shall respond in writing, stating the reasons this TER was not approved. For variations in state and local codes, if any see [Section 8](#).

² <http://www.structuremag.org/wp-content/uploads/2014/08/C-StructuralPerformance-Nelson-Aug081.pdf>

³ <http://www.sbcmag.info/article/2014/seismic-design-coefficients-how-they-are-determined-light-frame-components>

Technical Evaluation Report (TER)

- 3.1.3. Resistance to transverse loads for wall assemblies used in light-frame cold-formed steel and wood construction in accordance with [IBC Section 1609.1.1](#).
 - 3.1.4. Performance for use as foam plastic insulation in accordance with the [IRC Section R316](#) and [IBC Section 2603](#).
 - 3.1.5. Performance for use as insulated sheathing in accordance with [IRC Section N1102](#) and [IECC Section C402.1](#).
 - 3.1.6. Performance for use as an air barrier in accordance with the [IECC Section C402.5.1.2.1](#).⁴
 - 3.1.7. Performance for use as a water-resistive barrier (WRB) in accordance with the [IRC Section R703.2](#) and [IBC Section 1404.2](#).
 - 3.1.8. Performance for use without a thermal barrier in accordance with *NFPA 286* and the acceptance criteria of [IBC Section 803.1.2](#).
 - 3.1.9. Performance for vertical and lateral fire propagation in accordance with *NFPA 285* and [IBC Section 2603.5.5](#).
- 3.2. Any code compliance issues not specifically addressed in this section are outside the scope of this TER.
4. **Product Description and Materials:**



Figure 1: Strong-R® Structural Insulation

- 4.1. Strong-R® Structural Insulation is a structural, rigid insulation sheathing product consisting of a proprietary fibrous sheathing board laminated to one side of a proprietary rigid foam plastic insulation.
 - 4.1.1. The proprietary fibrous sheathing is made of specially treated plies that are pressure-laminated with a water-resistant adhesive. The surface finish consists of a facer on one or both side using a 0.113" (2.9 mm) nominal thickness fibrous sheathing board.
 - 4.1.2. The rigid foam plastic insulation is a Class A proprietary polyisocyanurate, which can have facings on one or both sides. The facers are designed with a base foil layer (0.0009 mil).
 - 4.2. **Material Availability**
 - 4.2.1. Thickness: up to 4.0" (102 mm)
 - 4.2.2. Standard product width: 48" (1219 mm)
 - 4.2.3. Standard lengths: 96", 108", and 120" (2438, 2743, and 3048 mm)
5. **Applications:**
- 5.1. **General**
 - 5.1.1. Strong-R® Structural Insulation is used in the following applications:
 - 5.1.1.1. Wall sheathing in buildings constructed in accordance with the *IRC and IBC* for light-frame steel and wood construction.
 - 5.1.1.2. Structural wall sheathing to provide lateral load resistance (wind and seismic) for braced wall panels used in light-frame construction.

⁴ [2009 IECC Section 402.4.2](#), [2012 IECC Section C402.4.1.2.1](#)

Technical Evaluation Report (TER)

- 5.1.1.3. Structural wall sheathing to provide resistance to transverse loads for wall assemblies used in light-frame construction.
 - 5.1.1.4. Insulating sheathing applied as in-fill to portions of walls that are not designed as braced wall panels or shear walls.
 - 5.1.1.5. Insulated sheathing in accordance with the [/IRC Section N1102](#) and [/IECC Section C402](#).
 - 5.1.1.6. An approved WRB in accordance with [/IRC Section R703.2](#) and [/IBC Section 1404.2](#) when installed with approved Construction Tape on all sheathing seams, see [Section 5.3.3](#). See the manufacturer's product information for further details.
 - 5.1.1.6.1. Where the joints are not taped, a separate WRB shall be installed in accordance with the WRB manufacturer's installation instructions.
 - 5.1.1.7. An air barrier material as part of an air barrier assembly in accordance with [/IRC Section N1102.4](#) and [/IECC Section 402](#) in accordance with the manufacturer's installation instructions and this TER.
- 5.1.2. Strong-R® Structural Insulation contains foam plastics complying with [/IRC Section R316](#) and [/IBC Section 2603](#).

5.2. Structural Applications

5.2.1. General Provisions

- 5.2.1.1. Except as otherwise described in this TER, Strong-R® Structural Insulation shall be installed in accordance with the applicable building codes listed in [Section 2](#) using the provisions set forth therein for light-frame construction.
- 5.2.1.2. Anchorage for in-plane shear shall be provided to transfer the induced shear force into and out of each shear wall.
 - 5.2.1.2.1. For wind design, anchor bolt spacing shall not exceed 6' o.c.
 - 5.2.1.2.2. For seismic design, anchor bolt spacing shall not exceed 4' o.c.
- 5.2.1.3. The maximum aspect ratio for Strong-R® Structural Insulation shall be 4:1.
- 5.2.1.4. The minimum full height panel width shall be 24".
- 5.2.1.5. All panel edges shall be supported by framing.
- 5.2.1.6. Fasteners may be countersunk beneath the outer surface of the foam plastic sheathing layer.
- 5.2.1.7. Where the application exceeds the limitations set forth herein, design shall be permitted in accordance with accepted engineering procedures, experience and technical judgment.

5.2.2. Steel-Framed Construction

- 5.2.2.1. Strong-R® Structural Insulation panels used in wall assemblies designed as shear walls:
 - 5.2.2.1.1. Are permitted to be designed using the capacities shown in [Table 1](#).
 - 5.2.2.1.2. Resist lateral wind load forces using the allowable shear loads (in pounds per linear foot) set forth in [Table 1](#).
 - 5.2.2.1.3. Resist seismic load forces using the seismic allowable unit shear capacities set forth in [Table 2](#) when seismic design is required in accordance with [/IBC Section 1613](#).
 - 5.2.2.1.3.1. The response modification coefficient, R, system overstrength factor, Ω_0 , and deflection amplification factor, C_d , indicated in [Table 2](#) shall be used to determine the base shear, element design forces, and design story drift in accordance with ASCE 7 Chapter 12 and Section 14.5.
- 5.2.2.2. Strong-R® Structural Insulation panels have the uplift capacities shown in [Table 3](#).

Technical Evaluation Report (TER)

5.2.2.3. Strong-R® Structural Insulation panels are permitted to resist transverse wind load forces using the allowable transverse loads (in pounds per linear foot) set forth in [Table 4](#). Required component and cladding loads to be resisted are found in [/RC Table R301.2\(2\)](#) and [R301.2\(3\)](#), and [IBC Section 1609.1.1](#).

Table 1: Strong-R® Structural Insulation Allowable Strength Design (ASD) Capacity – Wind

Stud Type	Structural Sheathing Product	Thickness (in)	Fastener Spacing (edge/field) (in)	Maximum Stud Spacing (in)	Gypsum Wallboard (GWB)	Gypsum Wallboard Fastener Spacing ³ (edge/field)	Allowable Unit Shear Capacity (plf)	Fastener Schedule
Steel ¹	Strong-R® Structural Insulation	1¼	3/3	24 o.c.	½" GWB	8/8	280	See Note 4
			3/3			8/12	290	
			3/3			6/12	325	
			3/3		No GWB ²	-	235	See Note 8
			3/3				140	
			3/3				395	See Note 6
			3/12				395	
			6/12				195	See Note 5
		12/12	105					
		2	3/3		395	See Note 6		
			3/12		395			
			6/12		195	See Note 5		
			12/12		105			
			3/3		260	See Note 7		
6/12	640		See Note 9					
Wood	1¼	3/12		320				
		6/12		640				
	2	3/12		640				
		6/12	320					

1. 20 ga. 50 ksi 3⁵/₈" metal studs @ 24" o.c.
2. Mid height horizontal brace installed every other cavity space.
3. Gypsum attached with minimum #6 type S screws 1¹/₄" long with a minimum edge distance of 3¹/₈".
4. #8 x 1⁵/₈" Self Drilling Modified Truss Head Screw (Head flush w/ exterior of foam board)
5. #8 x 1⁵/₈" Self Drilling Modified Truss Head Screw (Head driven through the foam plastic to seat against the backer material)
6. #8 x 2¹/₂" Self Drilling Modified Truss Head Screw (Head driven through the foam plastic to seat against the backer material)
7. #8 x 3" Self Drilling Modified Truss Head Screw (Head flush w/ exterior of foam board)
8. 0.100" Diameter x 1-1¹/₂" Length Pins (Bostitch® C4S100 BG)
9. Minimum #8 x 1¼" Wafer Head Screw (Screw shall penetrate a minimum of 1" into the stud and head shall be driven through the foam plastic to seat against the backer material.)
Fastener edge distance shall be a minimum of 3¹/₈".

Technical Evaluation Report (TER)

Table 2: Seismic Allowable Unit Shear Capacity & Seismic Design Coefficients for Strong-R® Structural Insulation⁶

Seismic Force Resisting System	Thickness (in)	Gypsum ⁵ Wallboard Fastening Schedule	Maximum stud spacing (in)	Seismic Allowable Unit Shear ⁷ Capacity (plf)	Apparent Shear Stiffness, G_a (kips/in)	Response Modification Factor, R^8	System Overstrength Factor, Ω_0^9	Deflection Amplification Coefficient, C_d^{10}	Structural System Limitations and Building Height (ft) Limit ^{11, 12, 13}					
									Seismic Design Category					
									B	C	D	E	F	
Light-Frame (cold formed steel ³) Walls Sheathed with Strong-R® Structural Insulation ¹	1¼	No GWB	24 o.c. ⁴	170	9	6.5	3	4	NL	NL	65	65	65	
		8:8	24 o.c.	225	14	6.5	3	4	NL	NL	65	65	65	
Light-Frame (wood) Walls Sheathed with Strong-R® Structural Insulation ²		No GWB	24 o.c. ⁴	200	10.3	2	2.5	2	NL	NL	35	NP	NP	

1. Strong-R® Structural Insulation attached with a minimum #8 x 1½" Self Drilling Modified Truss Head Screw. Fasteners spaced a maximum of 3" o.c. at the panel edges and 3" o.c. in the field. Fastener edge distance shall be a minimum of ¾". Fastener head shall be in contact with the panel surface. Alternately, fastener heads are permitted to be overdriven into foam portion of the panel with no reduction in shear capacities.
2. Strong-R® Structural Insulation attached with a minimum #8 x 1¼" Wafer Head Screw shall penetrate a minimum of 1" into the stud. Fasteners are to be installed spaced a maximum of 6" o.c. at the panel edges and 12" o.c. in the field. Fastener edge distance shall be a minimum of ¾". Fastener head shall be driven through the foam plastic to seat against the backer material.
3. 20 ga. 50 ksi 3-5/8" metal studs @ 24" o.c.
4. Mid height horizontal brace installed every other cavity space.
5. Walls installed with minimum ½" Gypsum wallboard attached with minimum #6 type S screws 1¼" long. Fasteners shall maintain a minimum edge distance of ¾".
6. All seismic design parameters follow the equivalency as defined in [Section 3](#) of this TER.
7. The allowable unit shear capacity is calculated using a factor of safety of 2.5 per ASCE 7.
8. Response modification coefficient, R, for use throughout ASCE 7. Note: R reduces forces to a strength level, not an allowable stress level.
9. The tabulated value of the overstrength factor, Ω_0 , is permitted to be reduced by subtracting one-half (0.5) for structures with flexible diaphragms.
10. Deflection amplification factor, C_d , for use with ASCE 7 Sections 12.8.6, 12.8.7, and 12.9.2.
11. Heights are measured from the base of the structure as defined in ASCE 7 Section 11.2.
12. NL = Not Limited
13. NP = Not permitted

Table 3: Uplift Performance of Strong-R® Structural Insulation

Structural Sheathing Product	Allowable Uplift Capacity (plf)	Maximum Stud Spacing (in)	Fastener Schedule
Light-Frame (cold formed steel) walls sheathed with Strong-R® Structural Insulation: Single Bottom Plate	220	24 o.c.	#8 x 1½" Zinc Coated Self Drilling Modified Truss Head Screw, 3" o.c. to perimeter/field

1. 20 ga. 50 ksi metal studs @ 24" o.c maximum.
2. The capacities shown are for the purpose of providing information on the hold-down capacity of the sheathing to the bottom plate connection independent of lateral loading. Where combined shear and uplift loading is needed, consult a professional engineer.

Technical Evaluation Report (TER)

Table 4: Transverse Load Performance of Strong-R® Structural Insulation for Resisting Out-of-Plane Wind Loads

Structural Sheathing Product	Allowable Design Value (psf)	Maximum Stud Spacing (in)	Fastener Schedule
Light-Frame (cold formed steel) walls sheathed with Strong-R® Structural Insulation	60	24 o.c.	#8 x 2½" Zinc Coated Self-Drilling Modified Truss Head Screw, 6" o.c. in perimeter and 12" o.c. in field
1. 20 ga. 50 ksi metal studs @ 24" o.c maximum. 2. The ASD allowable uniform load capacities to be used for wind design are determined by dividing the nominal uniform load capacities in Table 1 by an ASD reduction factor of 1.6, per <i>SDPWS</i> Section 3.2.1 for determining the ASD allowable uniform load capacity.			

Table 5: Basic Wind Speed (mph) for Strong-R® Structural Insulation Used in Exterior Wall Covering Assemblies

Structural Sheathing Product	Allowable Components & Cladding Basic Wind Speed V_{asd} per <i>ASCE 7-05</i> (mph)	Allowable Components & Cladding Basic Wind Speed V_{ult} per <i>ASCE 7-10</i> (mph)
	24" o.c. Framing	24" o.c. Framing
Strong-R® Structural Insulation	136	175
1. Allowable wind speeds are based on the following: Components and Cladding wind loads, Zone 4, Mean roof height 30', Exposure B, 10 sq. ft. effective wind area. See the applicable building code for any adjustment needed for specific building location and configuration. 2. Design wind load capacity shall be in accordance with IBC Section 1609.1.1 .		

5.3. Water-Resistive Barrier

- 5.3.1. Strong-R® is an approved WRB in accordance with [IRC Section R703.2](#) and [IBC Section 1404.2](#) when installed with White 3M™ Venture 1558 HT, Venture 1520 CW Aluminum Foil Sheathing Tape or equivalent on all sheathing seams, 4" wide self-adhered flashing tape meeting AAMA 711 (3M™ All Weather Flashing Tape 8067 or equivalent) with release liner may be required for effective taping of inside and outside corners. See the [manufacturer's product information](#) for further details.
- 5.3.2. Strong-R® shall be installed with board joints placed directly over exterior framing spaced a maximum of 24" (610 mm) o.c. The fasteners used to attach the board shall be installed in accordance with [Section 6](#).
- 5.3.3. A separate WRB may also be provided. If a separate WRB method is used, taping of the sheathing joints is not required.
- 5.3.4. Flashing of penetrations shall comply with the applicable code and must be installed at all sheathing penetrations. Use qualified flashing material such as self-adhered flashing tape meeting AAMA 711 (3M™ All Weather Flashing Tape 8067 or equivalent). See [Figure 2](#), [Figure 3](#) and [Figure 4](#) for typical penetration flashing details.
- 5.3.5. Flashing Details – Typical Flanged and Unflanged Penetration and Flanged Window

Technical Evaluation Report (TER)



STEP 1

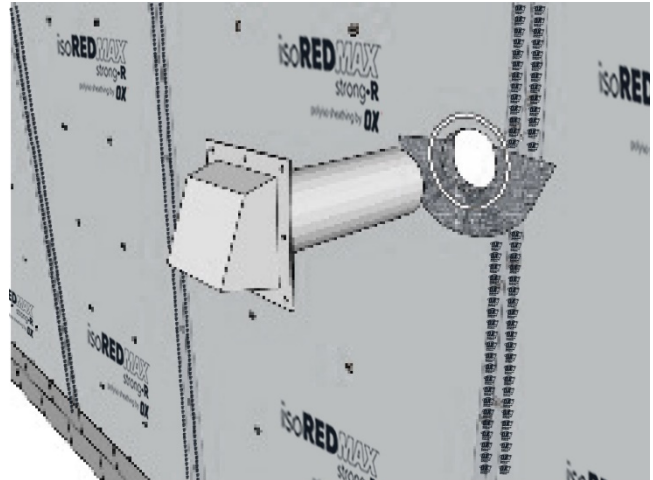

STEP 2

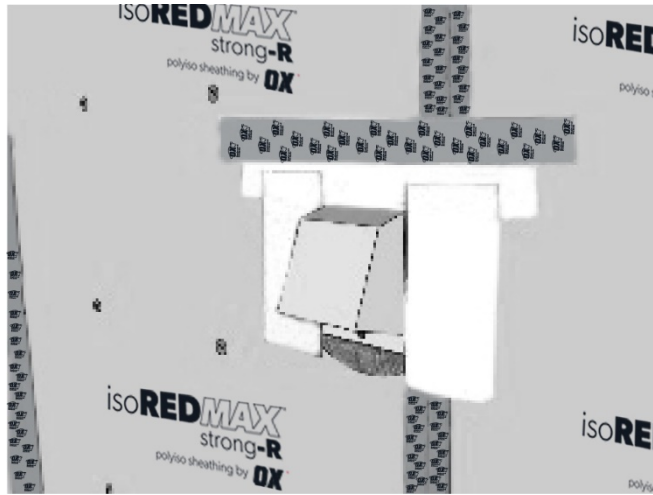

STEP 3

Figure 2: Typical Penetration Flashing Detail – Flanged

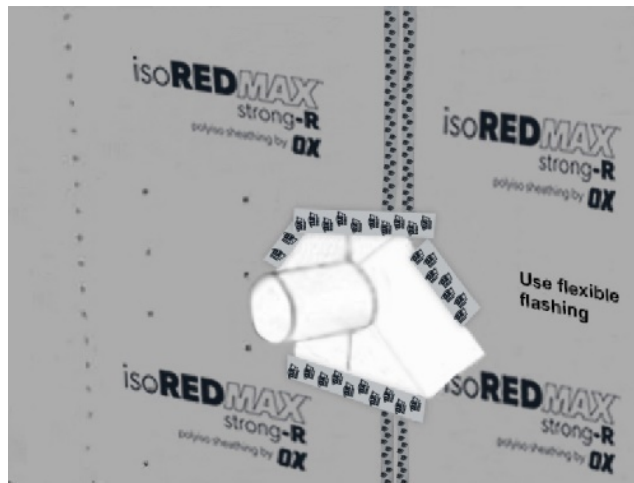

Figure 3: Typical Penetration Flashing Detail – Unflanged

Technical Evaluation Report (TER)

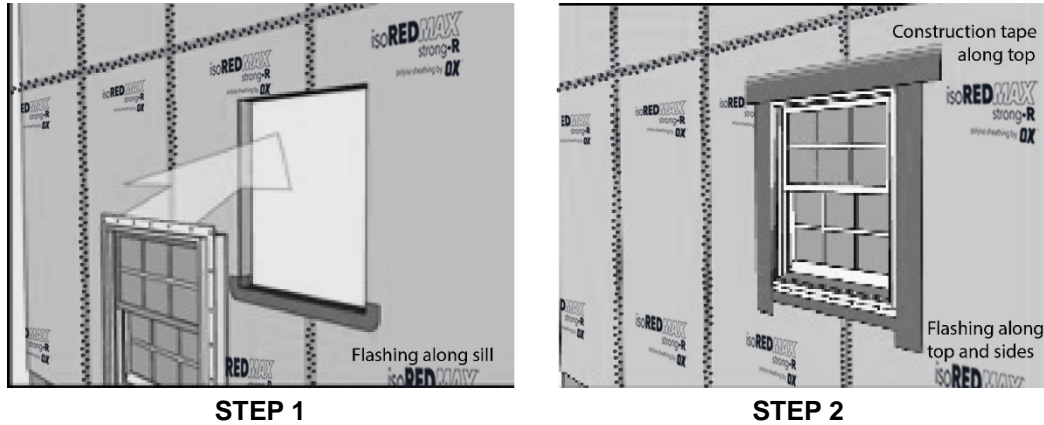

Figure 4: Typical Window Flashing Detail

5.4. Thermal Resistance (R-Value)

- 5.4.1. Strong-R® is a FPIS panel used as thermal insulation in wall, roof and ceiling assemblies.
- 5.4.2. Strong-R® meets the continuous insulating sheathing requirements complying with the provisions of [IRC Section N1102](#) and [IECC Section C402](#).
- 5.4.3. Strong-R® Structural Insulation has the thermal resistance shown in [Table 6](#).

Table 6: Strong-R® Structural Insulation Thermal Resistance Properties

Thickness (in)	R-Value (h·ft ² ·°F/Btu)
2.0	13.0
1.25	7.5
<small>1" = 25.4 mm, 1 °F.ft².h/Btu = 0.176 °K.m².h/W 1. Thermal values are determined using the ASTM C518 test method at 75°F mean temperature on material conditioned according to ASTM C1289 Section 11.1 (Degrees F.ft².h/Btu).</small>	

5.5. Air Barrier

- 5.5.1. Wall and ceiling assemblies constructed with Strong-R® are used to meet air barrier requirements in accordance with [IECC Section C402](#).
- 5.5.2. All penetrations shall be flashed and sealed in accordance with the flashing manufacturer's installation instructions. Self-adhered flashing tape shall meet AAMA 711 (FortiFlash® Butyl or equivalent).
- 5.5.3. Strong-R® is defined as an air barrier material having an air permeance of less than 0.02 L/m².ft., in accordance with [IECC Section C402.5](#).

5.6. Surface Burn Characteristics

- 5.6.1. Strong-R® has the flame spread and smoke developed ratings as shown in [Table 7](#), when tested in accordance with ASTM E84 per [IRC Section R316.3](#) and [IBC Section 2603.3](#).

Table 7: Fire Performance of Strong-®R

Product	Flame Spread	Smoke Developed
Strong-R® ¹	< 25	< 450
<small>1" = 25.4 mm 1. Foam plastic core tested in accordance with ASTM E84, with maximum foam thickness of 4".</small>		

Technical Evaluation Report (TER)

5.7. Thermal Barrier

- 5.7.1. Strong-R® boards with a maximum thickness of 4" were tested in accordance with *NFPA 286* and have met the acceptance criteria of [IBC Section 803.1.2.1](#) for use on walls only or ceilings only without a thermal barrier, in accordance with [IBC Section 2603.4](#) and [2603.5.2](#).

5.8. Non-Structural Applications

- 5.8.1. Where other means of wall bracing are provided, or are not required, and an approved exterior wall covering capable of separately resisting loads perpendicular to the face of the walls is installed over the sheathing, Strong-R® Structural Insulation may be installed in accordance with [Section 6.6](#).

5.9. Vertical and Lateral Fire Propagation

- 5.9.1. Strong-R® was tested to assess performance with regard to vertical and lateral fire propagation in accordance with *NFPA 285* and [IBC Section 2603.5.5](#).
- 5.9.2. Engineering analysis has also been conducted to assess substitution of other products within the approved wall assemblies.
- 5.9.3. The wall assemblies listed in [Table 8](#) and [Table 9](#) are approved for use in buildings of Type I-IV construction.

Table 8: Approved *NFPA 285* Wall Assemblies – Brick Cladding¹

Wall Component	Materials
Base Wall System Use either 1, 2, 3 or 4 Note: May use 4 optionally when FRTW framing is allowed by code.	1. Cast Concrete Wall 2. Concrete Masonry Wall 3. 20-gauge (min.) 3 ⁵ / ₈ " (min.) steel studs spaced 24" o.c. (max) <ul style="list-style-type: none"> a. 1 layer – 5⁸/₈"-thick Type X gypsum wallboard on interior b. Lateral bracing every 4' 4. Where allowed in Types I-IV construction, FRTW (Fire Retardant Treated Wood) studs complying with IBC Section 2303.2, minimum nominal 2x4 spaced at a maximum 16" o.c. <ul style="list-style-type: none"> a. 5⁸/₈" (min.) Type X gypsum wallboard interior. b. Wall braced at mid-height and fire-stopped at top and bottom.
Fire-Stopping in Stud Cavities at Floor Lines. Use 2 with FRTW framing.	1. Any approved 4 pcf mineral fiber based safining insulation in each stud cavity at floor line. Safing thickness must match stud cavity depth. 2. Solid FRTW fire blocking at floor line when Base Wall System, Item 4 is used.
Cavity Insulation Use any option 1-13	1. None 2. 1½" (min.) BASF Wallite™ 2 pcf SPF (or equivalent) up to full cavity fill. 3. 1½" (min.) Premium Spray Products Foamsulate 20 up to full cavity fill. 4. Any noncombustible insulation per <i>ASTM E136</i> . 5. Any mineral fiber (Batt or board type Class A <i>ASTM E84</i> faced or unfaced). 6. Any fiberglass (Batt type Class A <i>ASTM E84</i> faced or unfaced). 7. Icynene Classic, Classic Plus, Classic Ultra or Classic Ultra Select; MD-R-210; MD-C-200; or Proseal. Partial cavity fill with a max. air space of 2" or full cavity fill not exceeding 7 ⁵ / ₈ ". Use with ½" exterior gypsum sheathing (min.). 8. NCFI Polyurethanes, full cavity depth or less of InsulBloc, InsulStar, InsulStar Plus or ThermalStop™ closed cell (2.0 lb/ft ³) spray polyurethane foam applied using sheathing as substrate and covering the width of the cavity. Use with ½" exterior gypsum sheathing (min.). 9. SWD Urethane Quik-Shield 112 spray polyurethane foam applied using 5 ⁸ / ₈ " Type X sheathing as substrate. Air gap must not exceed 2½". 10. Demilec Sealection 500 or HeatLok Soy 200, up to full cavity fill. Use with 5 ⁸ / ₈ " Type X exterior gypsum sheathing. 11. Accella Polyurethane Bayseal® OC and OCX or Bayseal® CC, up to full cavity fill using minimum ½" exterior gypsum sheathing. 12. Lapolla™ Foam-Lok™ FL 2000 with 5 ⁸ / ₈ " Type X exterior sheathing in 3 ⁵ / ₈ " studs (max.) 13. Any cavity insulation which has been tested per <i>ASTM E1354</i> (at a min. of 20 kw/m ² heat flux) and shown by analysis to be of equivalent or lesser flammability (based on T _{ign} , Pk. HRR) than the foam tested in Item 2 or 3 above.

Technical Evaluation Report (TER)

Wall Component	Materials
<p>Exterior Sheathing Use either 1, 2 or 3 (with limitations noted in Cavity Insulation Allowances)</p> <p>Note: Exterior FRTW sheathing or gypsum wallboard is optional for Base Walls 1 and 2.</p>	<ol style="list-style-type: none"> 1. None 2. Minimum 1/2" exterior gypsum sheathing (unless 5/8" Type X exterior sheathing is otherwise specified with cavity insulations). 3. 1/2" (min.) FRTW structural panels complying with IBC section 2303.2 and installed in accordance with the code requirements for Types I-IV construction.
<p>Water-Resistive Barrier Over Base Wall Use either 1, 2 or 3</p> <p>Note: Item 3 applies when exterior gypsum sheathing is used.</p>	<ol style="list-style-type: none"> 1. None 2. WRB's over Steel Framing: <ol style="list-style-type: none"> a. Kingspan GreenGuard® Max Building Wrap b. Dupont Tyvek (Various per ESR 2375) c. Dow Weathermate™ d. Dow Weathermate™ Plus e. Ox ThermoPly 3. WRBs over exterior sheathing: <ol style="list-style-type: none"> a. Henry Air Bloc 32MR b. Henry Foilskin c. Henry MetalClad d. CCW 705 FR-A e. Kingspan GreenGuard® Max Building Wrap f. Dupont Tyvek (various per ESR-2375) g. Dow Weathermate™ h. Dow Weathermate™ Plus i. Any WRB that has been tested per <i>ASTM E1354</i> (at a min. of 20 kw/m² heat flux) and shown by analysis to be of equivalent or lesser flammability (based on T_{ign}, Pk. HRR) than the exterior insulation foam core or baseline Item 3a above.
<p>Exterior Insulation</p>	<p>Up to 4"-thick OX Strong-R®, consisting of a single panel or multiple thinner panels</p>
<p>WRB Over Exterior Insulation Use either 1 or 2</p>	<ol style="list-style-type: none"> 1. Aluminum construction tape as tested (or equivalent), max. 6" wide over staggered insulation joints. 2. For use with all Exterior Cladding options as written below: <ol style="list-style-type: none"> a. Henry Foilskin b. Henry MetalClad c. CCW 705 FR-A d. Kingspan GreenGuard® Max Building Wrap e. Dupont Tyvek (various per ESR-2375) f. Dow Weathermate™ g. Dow Weathermate™ Plus h. Any WRB which has been tested per <i>ASTM E1354</i> (at a min. of 20 kw/m² heat flux) and shown by analysis to be of equivalent or lesser flammability (based on T_{ign}, Pk. HRR) than those listed above.
<p>Exterior Cladding Use 1 through 6</p> <p>Note: Masonry cladding items 2-6 do not employ an air gap or open joints.</p>	<ol style="list-style-type: none"> 1. Brick – Nominal 4" clay brick or veneer with max. 2" air gap behind the brick. Brick ties/anchors 24" o.c. (max.). 2. Stucco – Minimum 3/4"-thick exterior cement plaster and lath with approved WRB over insulation. 3. Limestone – Minimum 2" thick, using any standard non-open joint installation technique such as shiplap. 4. Natural Stone Veneer – Minimum 2" thick using any standard non-open joint installation technique. 5. Terracotta Cladding – Minimum 1 1/4" thick (solid or equivalent by weight) using any standard non-open joint installation technique such as shiplap. 6. Cast Artificial Stone – Minimum 1 1/2" thick complying with <i>ICC-ES AC51</i> installed using any standard non-joint installation technique such as shiplap.
<p>1. The assemblies' combinations created herein and the various substitutions of products are based on testing and professional thermal engineering analysis by Priest & Associates Consulting, LLC.</p> <p>2. Acceptance criteria for <i>ASTM E1354</i> testing have not been well established in the referenced building codes and foam sheathing related sections. The criteria stated here for substitution of products is based on testing and professional thermal engineering analysis by Priest & Associates.</p> <p>3. T_{ign} is the time to ignition from the start of the test until the sheathing ignites. Pk. HRR is the peak heat release rate during the test.</p>	

Technical Evaluation Report (TER)

Table 9: Approved *NFPA 285* Wall Assemblies – ACM Cladding¹

Wall Component	Materials
<p>Base Wall System Use either 1, 2, 3 or 4</p> <p>Note: May use 4 optionally when FRTW framing is allowed by code</p>	<ol style="list-style-type: none"> 1. Cast Concrete Wall 2. Concrete Masonry Wall 3. 20-gauge (min.) 3⁵/₈" (min.) steel studs spaced 24" o.c. (max) <ol style="list-style-type: none"> a. 1 layer – 5⁸/₈"-thick Type X gypsum wallboard on interior b. Lateral bracing every 4' 4. Where allowed in Types I-IV construction, FRTW (Fire Retardant Treated Wood) studs complying with IBC Section 2303.2, minimum nominal 2x4 spaced at a maximum 16" o.c. <ol style="list-style-type: none"> a. 5⁸/₈" (min.) Type X gypsum wallboard interior. b. Wall braced at mid-height and fire-stopped at top and bottom.
<p>Fire-Stopping in Stud Cavities at Floor Lines. Use 2 with FRTW framing.</p> <p>Use either 1 or 2. As an option, use 2 with FRTW framing</p>	<ol style="list-style-type: none"> 1. Any approved 4 pcf mineral fiber based safing insulation in each stud cavity at floor line. Safing thickness must match stud cavity depth. 2. Solid FRTW fire blocking at floor line when Base Wall System, Item 4 is used.
<p>Cavity Insulation Use any option 1-13</p>	<ol style="list-style-type: none"> 1. None 2. 1½" (min.) BASF Wallite™ 2 pcf SPF (or equivalent) up to full cavity fill. 3. 1½" (min.) Premium Spray Products Foamsulate 20 up to full cavity fill. 4. Any noncombustible insulation per <i>ASTM E136</i>. 5. Any mineral fiber (Batt or board type Class A <i>ASTM E84</i> faced or unfaced). 6. Any fiberglass (Batt type Class A <i>ASTM E84</i> faced or unfaced). 7. Icynene Classic, Classic Plus, Classic Ultra or Classic Ultra Select; MD-R-210; MD-C-200; or Proseal. Partial cavity fill with a max. air space of 2" or full cavity fill not exceeding 7⁵/₈". Use with ½" exterior gypsum sheathing (min.). 8. NCFI Polyurethanes, full cavity depth or less of InsulBloc, InsulStar, InsulStar Plus or ThermalStop™ closed cell (2.0 lb/ft³) spray polyurethane foam applied using sheathing as substrate and covering the width of the cavity. Use with ½" exterior gypsum sheathing (min.). 9. SWD Urethane Quik-Shield 112 spray polyurethane foam applied using 5⁸/₈" Type X sheathing as substrate. Air gap must not exceed 2½". 10. Demilec Sealection 500 or HeatLok Soy 200, up to full cavity fill. Use with 5⁸/₈" Type X exterior gypsum sheathing. 11. Accella Polyurethane Bayseal® OC and OCX or Bayseal® CC, up to full cavity fill using minimum ½" exterior gypsum sheathing. 12. Lapolla™ Foam-Lok™ FL 2000 with 5⁸/₈" Type X exterior sheathing in 3⁵/₈" studs (max.) 13. Any cavity insulation which has been tested per <i>ASTM E1354</i> (at a min. of 20 kw/m² heat flux) and shown by analysis to be of equivalent or lesser flammability (based on T_{ign}, Pk. HRR) than the foam tested in Item 2 or 3 above.
<p>Exterior Sheathing Use either 1, 2 or 3</p> <p>Note: Exterior FRTW sheathing or gypsum wallboard is optional for Base Walls 1 and 2.</p>	<ol style="list-style-type: none"> 1. Minimum ½" exterior gypsum sheathing (5⁸/₈" Type X exterior gypsum sheathing required when SPF in cavity). 2. ½" (min.) FRTW structural panels complying with IBC section 2303.2 and installed in accordance with the code requirements for Types I-IV construction.
<p>Water-Resistive Barrier Over Base Wall Use any item 1-8</p>	<ol style="list-style-type: none"> 1. None 2. Any WRB that has been tested per <i>ASTM E1354</i> (at a min. of 20 kw/m²) and shown by analysis to be of equivalent or lesser flammability (based on T_{ign}, Pk. HRR) than the exterior insulation foam core or baseline Item 3 below. 3. Henry Air Bloc 32MR 4. Kingspan GreenGuard® Max Building Wrap 5. Dupont Tyvek (Various per ESR-2375) 6. Dow Weathermate™ 7. Dow Weathermate™ Plus 8. WRBs over exterior sheathing: <ol style="list-style-type: none"> j. Henry Foilskin k. Henry MetalClad l. CCW 705 FR-A

Technical Evaluation Report (TER)

Wall Component	Materials
	<ul style="list-style-type: none"> m. Kingspan GreenGuard® Max Building Wrap n. Dupont Tyvek (various per ESR-2375) o. Dow Weathermate™ p. Dow Weathermate™ Plus
Exterior Insulation	Up to 4"-thick OX Strong-R®, consisting of a single panel or multiple thinner panels
WRB Over Exterior Insulation Use any item 1-5	<ul style="list-style-type: none"> 1. None 2. Aluminum construction tape as tested (or equivalent), max. 6" wide over staggered insulation joints. 3. Henry Foilskin 4. Henry MetalClad 5. CCW 705 FR-A
Exterior Cladding Use any item 1-11	<ul style="list-style-type: none"> 1. Brick – Nominal 4" clay brick or veneer with max. 2" air gap behind the brick. Brick ties/anchors 24" o.c. (max.). 2. Stucco – Minimum 3/4"-thick exterior cement plaster and lath with an optional secondary water resistive barrier between the exterior insulation and lath. The secondary barrier shall not be full coverage asphalt or self-adhered butyl membrane. 3. Limestone – Minimum 2" thick, using any standard installation technique. 4. Natural Stone Veneer – Minimum 2" thick using any standard installation technique. 5. Cast Artificial Stone – Minimum 1 1/2" thick complying with <i>ICC-ES AC51</i> installed using any standard installation technique. 6. Terracotta Cladding – Minimum 1 1/4" thick, using any standard installation technique. 7. Any MCM, ACM (aluminum, steel, copper, zinc) (w/ 1 1/2" ± 1/2" air gap) that has successfully passed <i>NFPA 285</i> using any standard installation technique. 8. Uninsulated sheet metal building panels including aluminum, steel or copper using any standard installation technique. 9. Uninsulated Fiber-cement siding using any standard installation technique. 10. Stone/Aluminum honeycomb composite building panels that have passed <i>NFPA 285</i> or equivalent (StoneLite Wall Panels by Stone Panels – ESR-1500) 11. Autoclaved-aerated-concrete (AAC) panels that have successfully passed <i>NFPA 285</i> using any standard installation technique.
<p>1. The assemblies' combinations created herein and the various substitutions of products are based on testing and professional thermal engineering analysis by Priest & Associates Consulting, LLC.</p> <p>2. Acceptance criteria for <i>ASTM E1354</i> testing have not been well established in the referenced building codes and foam sheathing related sections. The criteria stated here for substitution of products is based on testing and professional thermal engineering analysis by Priest & Associates.</p> <p>3. T_{ign} is the time to ignition from the start of the test until the sheathing ignites. Pk. HRR is the peak heat release rate during the test.</p>	

6. Installation:

6.1. General

- 6.1.1.** Installation shall comply with the manufacturer's installation instructions and this TER. In the event of a conflict between the manufacturer's installation instructions and this TER, the more restrictive shall govern.

6.2. Orientation

- 6.2.1.** Strong-R® Structural Insulation may be installed vertically or horizontally over studs, with framing not less than 20 ga. 50 ksi 3⁵/₈" and spaced a maximum of 24" o.c. (610 mm) or wood framing that has a nominal thickness of not less than 2" (51 mm) and spaced a maximum of 24" o.c. (610 mm).
- 6.2.2.** Sheathing joints must be butted at framing members, and all panel edges shall be blocked. A single row of fasteners must be applied to each panel edge into the stud or blocking below. Do not tack product to framing, but fasten each panel completely after fastening begins.

Technical Evaluation Report (TER)

6.3. Attachment

6.3.1. Strong-R® Structural Insulation

6.3.1.1. Minimum #8 x 1⁵/₈" self-drilling modified truss head screw or 0.100" diameter x 1½" length pins (Bostitch® C4S100 BG) for steel studs.

6.3.1.1.1. Fastener spacing shall be a maximum of 12" o.c. (305 mm) along the edge and 12" o.c. in the field or as required in [Section 5](#) for the application selected.

6.3.1.2. Minimum #8 x 1¼" Wafer Head Screw for wood studs.

6.3.1.2.1. Fasteners shall penetrate a minimum of 1" into the stud. Fasteners are to be installed spaced a maximum of 6" o.c. (152 mm) at the panel edges and 12" o.c. (305 mm) in the field. Fastener edge distance shall be a minimum of ¾" (9.5 mm). Fastener head shall be driven through the foam plastic to seat against the backer material.

6.3.2. Gypsum Wallboard

6.3.2.1. Where required, gypsum wallboard shall be a minimum ½" thickness and shall be attached as follows:

6.3.2.1.1. #6 x 1¼" Type S screws

6.3.2.1.2. Fastener spacing shall be as shown in [Section 5](#).

6.4. Treatment of Joints

6.4.1. Strong-R® Structural Insulation sheathing joints must be butted at framing members, and a single row of fasteners must be applied to each panel edge into the stud below.

6.4.2. If Strong-R® Structural Insulation is being used as a WRB, joints must be taped as specified in [Section 5.3.1](#). If a separate WRB method is used, taping of the sheathing joints is not required.

6.5. Window Treatments

6.5.1. Strong-R® Structural Insulation must be installed with appropriate flashing and counter flashing in conformance with accepted building standards and in compliance with local building codes and the flashing manufacturer's installation instructions.

6.6. Non-Structural Applications

6.6.1. Install panels with minimum #8 x 1⁵/₈" self-drilling modified truss head screw or 0.100" diameter x 1½" length pins (Bostitch® C4S100 BG).

6.6.2. The fastener spacing shall be 12" o.c. along the top, bottom and vertical panel edges and 12" o.c. in the field. Do not tack product to framing, but fasten each panel completely after fastening begins.

7. Test and Engineering Substantiating Data:

7.1. Lateral load testing and data in accordance with *ASTM E564* and *E2126*.

7.2. Transverse load testing in accordance with *ASTM E330*.

7.3. Test reports and data for determining use as a WRB material, in accordance with *ASTM E331*.

7.4. Test reports and data for determining use as a component of an air barrier, in accordance with *ASTM E2178*.

7.5. Test reports and data for determining surface burning characteristic in accordance with *ASTM E84*.

7.6. Test reports and data for determining use in attics and crawlspaces without a thermal barrier or ignition barrier in accordance with *NFPA 286*.

7.7. Test reports and engineering analysis of vertical and lateral fire propagation properties in accordance with *NFPA 285*

7.7.1. Test reports and data for determining comparative equivalency for use as an alternative material in accordance with [IRC Section R104.11](#) and [IBC Section 104.11](#).

7.8. Manufacturer installation recommendations for structural sheathing on exterior walls.

Technical Evaluation Report (TER)

- 7.9. Quality Control Manual in accordance with a third-party quality control program with inspections conducted by an approved agency.
- 7.10. The product(s) evaluated by this TER fall within the scope of one or more of the model, state or local building codes for building construction. The testing and/or substantiating data used in this TER is limited to buildings, structures, building elements, construction materials and civil engineering related specifically to buildings.
- 7.11. The provisions of model, state or local building codes for building construction do not intend to prevent the installation of any material or to prohibit any design or method of construction. Alternatives shall use consensus standards, performance-based design methods or other engineering mechanics based means of compliance. This TER assesses compliance with defined standards, accepted engineering analysis, performance-based design methods, etc. in the context of the pertinent building code requirements.
- 7.12. Some information contained herein is the result of testing and/or data analysis by other sources, which DrJ relies on to be accurate, as it undertakes its engineering analysis.
- 7.13. DrJ has reviewed and found the data provided by other professional sources are credible. The information in this TER conforms to DrJ's procedure for acceptance of data from approved sources.
 - 7.13.1. DrJ's responsibility for data provided by approved sources conforms to [IBC Section 1703](#) and any relevant professional engineering law.
- 7.14. Where appropriate, DrJ's analysis is based on design values that have been codified into law through codes and standards (e.g., *IRC, WFCM, IBC, SDPWS, NDS[®], ACI[®], AISI, PS-20, PS-2*, etc.). This includes review of code provisions and any related test data that aids in comparative analysis or provides support for equivalency to an intended end-use application. Where the accuracy of design values provided herein is reliant upon the published properties of commodity materials (e.g. lumber, steel, concrete, etc), DrJ relies upon grade/properties provided by the raw material supplier to be accurate and conforming to the mechanical properties defined in the relevant material standard.

8. Findings

- 8.1. When installed in accordance with the manufacturer's installation instructions and this TER, Strong-R[®] Structural Insulation comply with, or are a suitable alternative to, the applicable sections of the codes listed in [Section 2](#) for the following applications.
 - 8.1.1. Lateral load resistance due to wind and seismic loads carried by shear walls.
 - 8.1.2. Transverse load resistance due to components and cladding pressures on building surfaces.
 - 8.1.3. Performance of the foam plastic component for conformance to [IRC Section R316](#) and [IBC Section 2603](#).
 - 8.1.4. Performance for use as insulating sheathing in accordance with [IRC Sections N1102.1](#) and [N1102.2](#) and [IECC Section C402](#).
 - 8.1.5. Performance for use as a WRB in accordance with [IRC Section R703.2](#) and [IBC Section 1404.2](#).
 - 8.1.6. Performance for use as an air barrier in accordance with [IRC Section N1102.4](#) and [IECC Section C402](#).
- 8.2. [IBC Section 104.11](#) ([IRC Section R104.11](#) and [IFC Section 104.9](#) are similar) states:

104.11 Alternative materials, design and methods of construction and equipment. The provisions of this code are not intended to prevent the installation of any material or to prohibit any design or method of construction not specifically prescribed by this code, provided that any such alternative has been *approved*. An alternative material, design or method of construction shall be *approved* where the *building official* finds that the proposed design is satisfactory and complies with the intent of the provisions of this code, and that the material, method or work offered is, for the purpose intended, not less than the equivalent of that prescribed in this code. ... Where the alternative material, design or method of construction is not *approved*, the *building official* shall respond in writing, stating the reasons the alternative was not *approved*.
- 8.3. This product has been evaluated in the context of the codes listed in [Section 2](#) and is compliant with all known state and local building codes. Where there are known variations in state or local codes that are applicable to this evaluation, they are listed here:
 - 8.3.1. No known variations

Technical Evaluation Report (TER)

8.4. This TER uses professional engineering law, the building code, ANSI/ASTM consensus standards and generally accepted engineering practice as its criteria for all testing and engineering analysis. DrJ's professional engineering work falls under the jurisdiction of each state Board of Professional Engineers, when signed and sealed.

9. Conditions of Use:

- 9.1. Where required by the authority having jurisdiction (AHJ) in which the project is to be constructed, this TER and the installation instructions shall be submitted at the time of permit application.
- 9.2. Any generally accepted engineering calculations needed to show compliance with this TER shall be submitted to the code official for review and approval.
- 9.3. Design loads shall be determined in accordance with the building code adopted by the jurisdiction in which the project is to be constructed.
- 9.3.1. This TER and the installation instructions shall be available to the jurisdiction in which the project is to be constructed.
- 9.3.2. Walls shall not be used to resist horizontal loads from concrete and masonry walls.
- 9.3.3. Strong-R® Structural Insulation shall not be used as a nailing base.
- 9.3.4. Except as provided in [Section 5.7](#), this product shall be fully protected from the interior of the building by an approved 15-minute thermal barrier where required by the applicable code.
- 9.3.5. In areas where the probability of termite infestation is very heavy, in accordance with [IBC Section 2603.8](#) or [IRC Section R318.4](#), the product must not be placed on exterior walls located within 6" (152 mm) of the ground.
- 9.3.6. Allowable shear loads shall not exceed values in [Table 1](#) for wind loads and [Table 2](#) for seismic loads.
- 9.3.7. Transverse design loads shall not exceed those described in [Table 4](#), unless an approved exterior wall covering capable of separately resisting loads perpendicular to the face of the walls is installed over the sheathing.
- 9.3.8. Strong-R® Structural Insulation are manufactured under a quality control program with quality control inspections in accordance with [IRC Section R109.2](#) and [IBC Sections 110.3.8](#) and [110.4](#).
- 9.4. When installed as a wall sheathing but not installed per structural requirements, light-framed walls shall be braced by other means.
- 9.5. When used as a WRB, installation shall be in accordance with [Section 5.3](#).
- 9.5.1. When used in accordance with the *IBC* in high wind areas, special inspections shall comply with [IBC Section 1705.11](#)⁵.
- 9.5.2. When used in accordance with the *IBC* in Seismic Design Categories C, D, E or F, special inspections shall comply with [IBC Section 1705.12](#)⁶.
- 9.6. Design
- 9.6.1. Building Designer Responsibility
- 9.6.1.1. Unless the AHJ allows otherwise, the Construction Documents shall be prepared by a Building Designer for the Building and shall be in accordance with [IRC Section R106](#) and [IBC Section 107](#).
- 9.6.1.2. The Construction Documents shall be accurate and reliable and shall provide the location, direction and magnitude of all applied loads and shall be in accordance with [IRC Section R301](#) and [IBC Section 1603](#).
- 9.6.2. Construction Documents
- 9.6.2.1. Construction Documents shall be submitted to the Building Official for approval and shall contain the plans, specifications and details needed for the Building Official to approve such documents.

⁵ [2012 IBC Section 1705.10](#)

⁶ [2012 IBC Section 1705.11](#)

Technical Evaluation Report (TER)

9.7. Responsibilities

- 9.7.1. The information contained herein is a product, material, detail, design and/or application TER evaluated in accordance with the referenced building codes, testing and/or analysis through the use of accepted engineering practice, experience and technical judgment.
- 9.7.2. DrJ TERs provide an assessment of only those attributes specifically addressed in the Products Evaluated or Code Compliance Process Evaluated sections.
- 9.7.3. The engineering evaluation was performed on the dates provided in this TER, within DrJ's professional scope of work.
- 9.7.4. This product is manufactured under a third-party quality control program in accordance with [/IRC Section R104.4](#) and [R109.2](#) and [/IBC Section 104.4](#) and [110.4](#).
- 9.7.5. The actual design, suitability and use of this TER, for any particular building, is the responsibility of the Owner or the Owner's authorized agent, and the TER shall be reviewed for code compliance by the Building Official.
- 9.7.6. The use of this TER is dependent on the manufacturer's in-plant QC, the ISO/IEC 17020 third-party quality assurance program and procedures, proper installation per the manufacturer's instructions, the Building Official's inspection and any other code requirements that may apply to demonstrate and verify compliance with the applicable building code.

10. Identification:

- 10.1. All Strong-R® Structural Insulation boards described in this TER are identified by a label on the board or packaging material bearing the manufacturer's name, product name, label of the third-party inspection agency, and other information to confirm code compliance.

10.1.1. Additional technical information can be found at oxengineeredproducts.com.

11. Review Schedule:

- 11.1. This TER is subject to periodic review and revision. For the most recent version of this TER, visit drjcertification.org.
- 11.2. For information on the current status of this TER, contact [DrJ Certification](#).



- [Mission, Belief and Independence](#)
- [Product Evaluation Policies](#)
- [Product Approval – Building Code, Administrative Law and P.E. Law](#)